

NOTE: TYPICAL SIZE FOR 1,500 GALLON GREASE TRAP IS 10'L X 5'W X 5'D.

3 ea. BAFFLE WALLS - TYP.

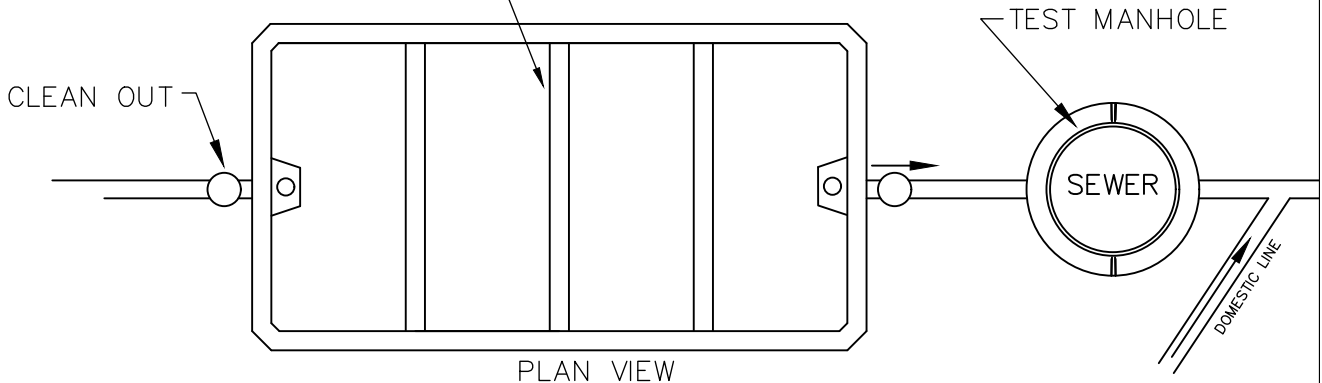

PLAN VIEW

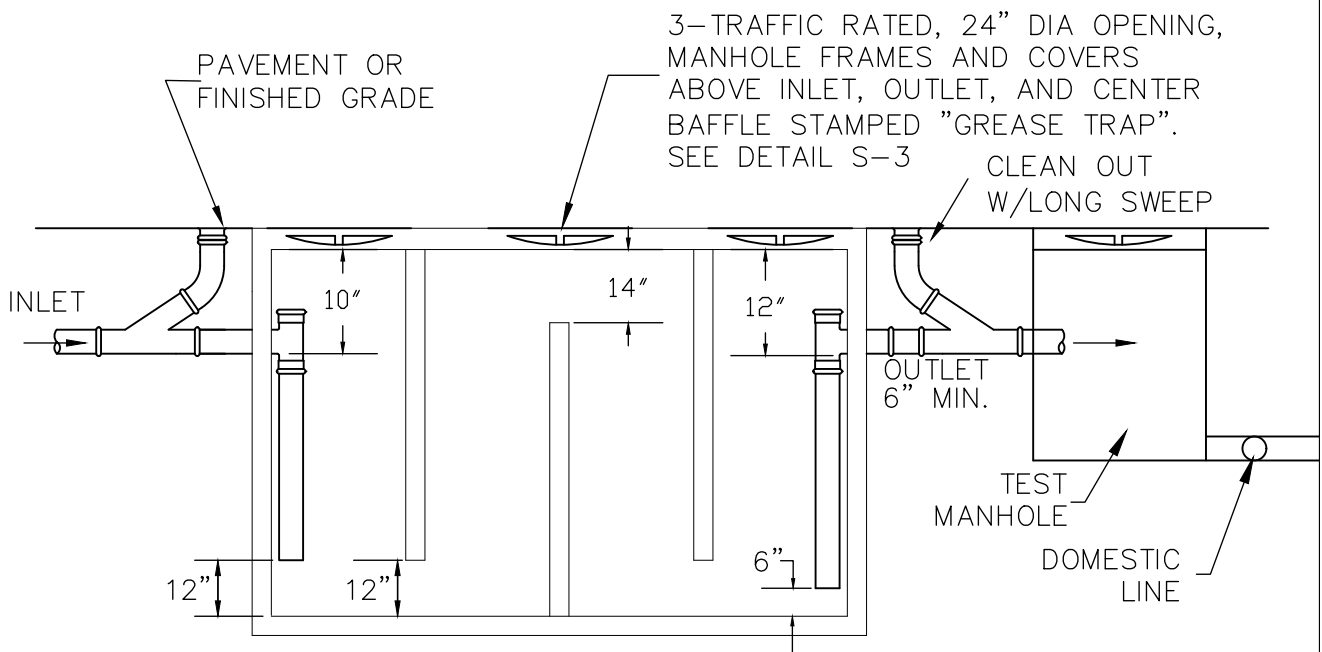

SECTION - VIEW

3-Traffic rated, 24" DIA opening, manhole frames and covers above inlet, outlet, and center baffle stamped "GREASE TRAP". SEE DETAIL S-3

NOTES:

1. MINIMUM CAPACITY OF 1500 GALLONS FOR ALL GREASE TRAPS.
2. DEVELOPER MUST SUBMIT GREASE TRAP DESIGN PRIOR TO DEVELOPMENT PERMIT ISSUANCE. SEE DETAIL S-25 FOR MINIMUM DESIGN CAPACITIES.
3. DEVELOPER MUST DESIGN ANY GREASE TRAP IN ACCORDANCE WITH DEPARTMENT OF HUMAN RESOURCES PUBLIC HEALTH, CHAPTER 290-5-26, SECTION D, GREASE TRAPS. DEVELOPER TO SUBMIT CALCULATIONS WITH DESIGN DRAWINGS PRIOR TO PERMITTING.

TOWN OF BRASELTON WATER & SEWER DEPARTMENTS

| | | | | | |
|----------------------------------|--|-----------------|-------------------------|---------------|---------|
| JOB TITLE STANDARD DETAIL | SHEET TITLE GREASE TRAP DETAIL | DRN. BY: EMI | REV. NO. | BY | DATE |
| | | CKD BY: | A | EMI | 3/13/07 |
| | | APPD. BY: | | | |
| | | DATE: MAY 2006 | | | |
| | | DETAIL No. S-24 | FILE No. 03033\S-24.dwg | SCALE: N.T.S. | |